

	S E L E C T	A	← Min=1.200mm Max=2.700mm	↑ Min=1.000mm Max=2.500mm	Min. Thickness: 5mm	Max. 667kg
		B	← Min=2.700mm Max=3.600mm	↑ Min=1.000mm Max=2.500mm		Max. 1.000 kg
		C	← Min=3.600mm Max=4.700mm	↑ Min=1.000mm Max=2.500mm		Max. 1.330 kg
		D	← Min=4.700mm Max=6.000mm	↑ Min=1.000mm Max=2.500mm		Max. 2.000 kg

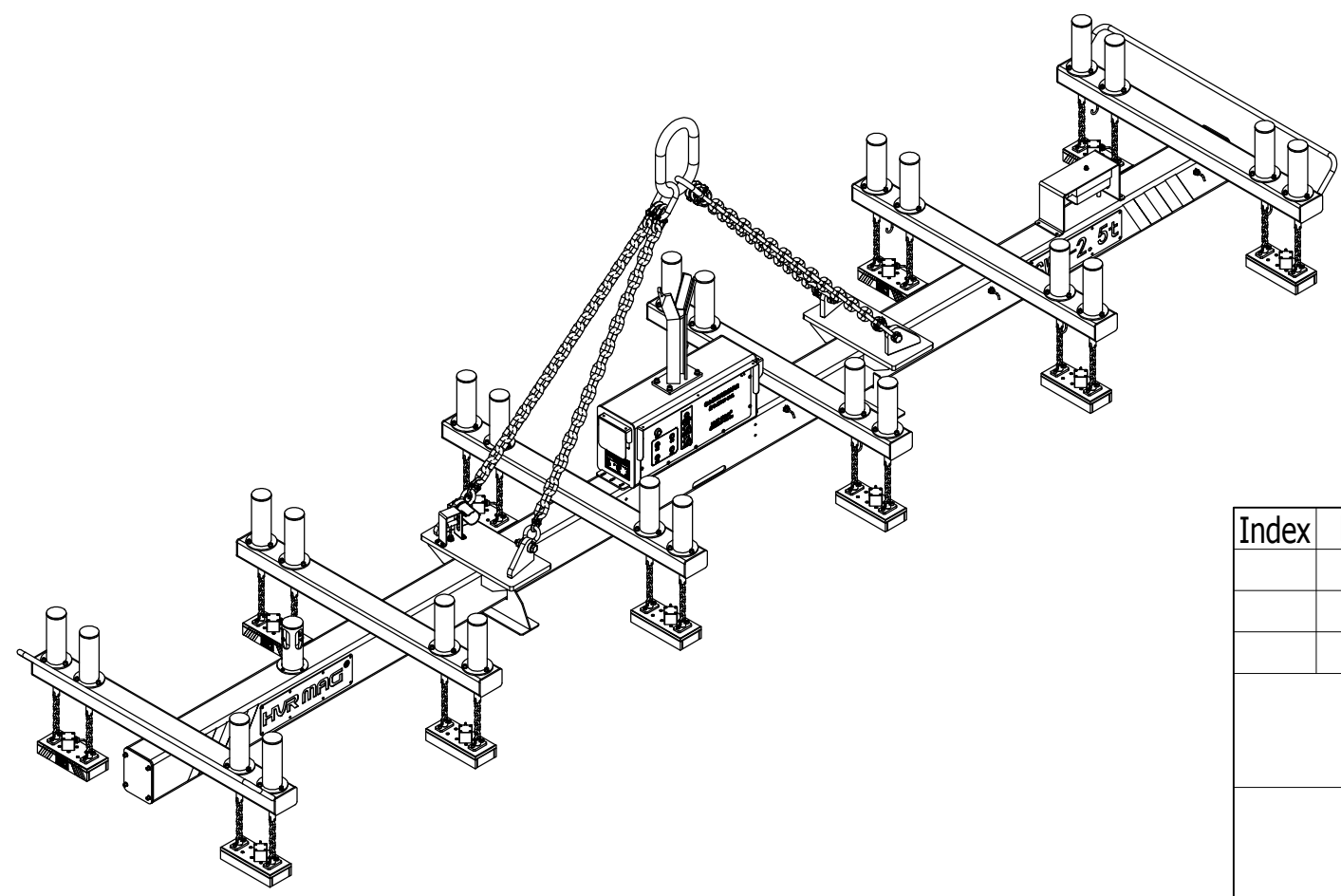
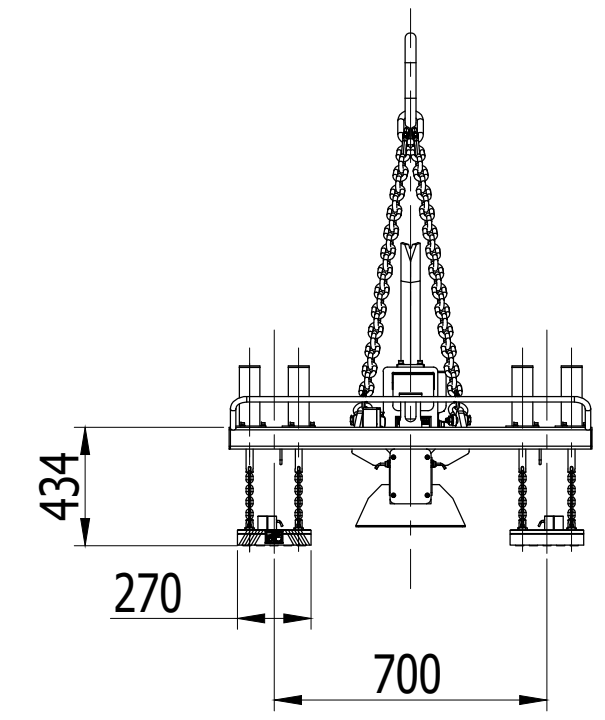
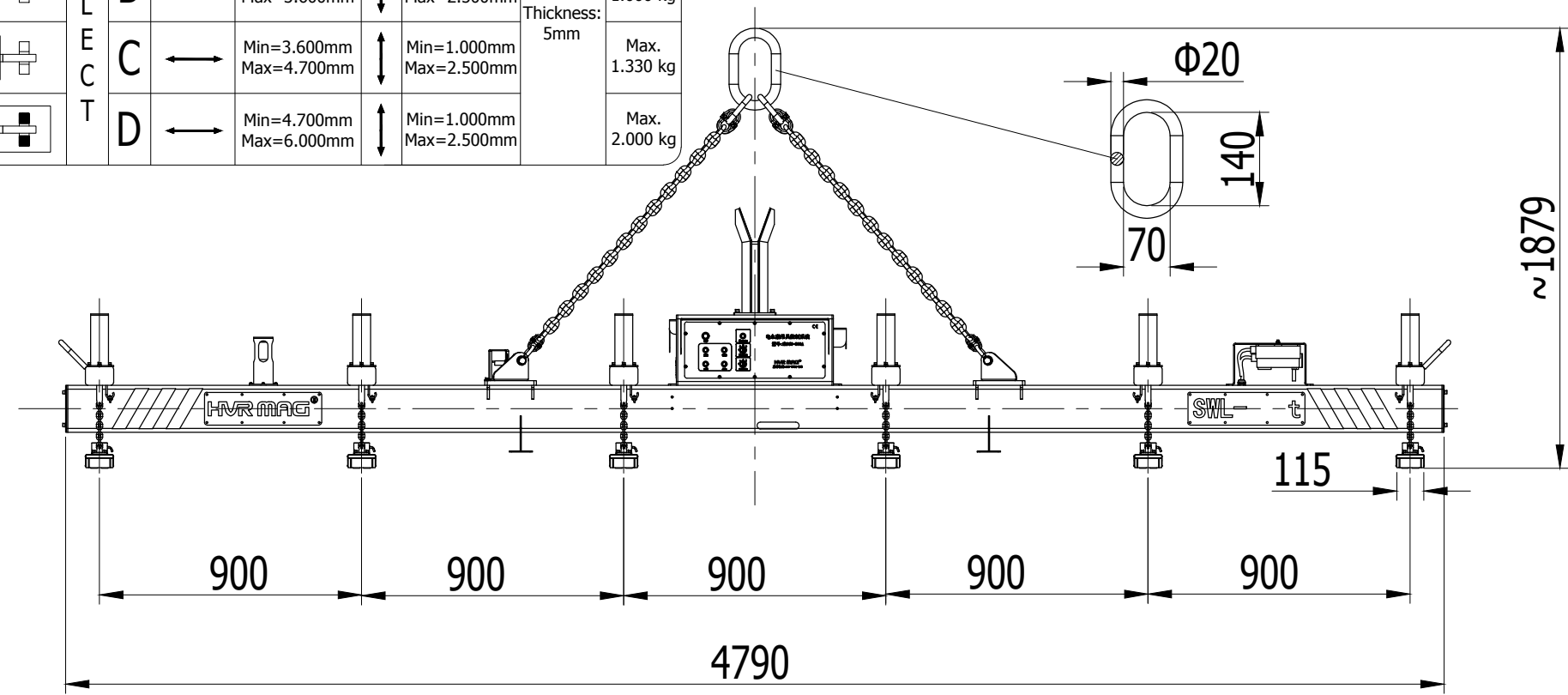

Indicative Weight: 700 kg

Indicative drawing. We reserve the right to modify the design at any time

Index	Date	Modification	Name
			<b>HVR MAG®</b>
			Date: 30/06/2020
			Scale: 1:40
<b>HM3-06-020</b> EPM beam for lifting of steel plate			Checked: BIN
			Unit:mm
			<b>HFA20142.00</b> Indicative drawing